

NIBIR CTFS (CU)

WALL-HUNG GAS BOILER WITH SEALED CHAMBER AND FORCED DRAUGHT WITH INSTANT DHW PRODUCTION



- ▶ **Mono-thermal, copper heat exchanger**
- ▶ **Compact dimension, only 250 mm deep**
- ▶ **LCD user interface with diagnostics**
- ▶ **Ambient temperature can be set from the boiler if an ambient probe is installed**
- ▶ **Ambient temperature probe supplied as standard**
-) Stainless steel plate DHW heat exchanger
-) Exclusive compact version circulation pump with integrated air purging device
-) LCD interface to view CH flow water temperature, DHW outlet temperature, failure codes, CH setting, DHW setting and operating status setting
-) Programmable parameters to adapt the boiler to the installation and alerts history
-) Hydraulic unit in composite material
-) Heating expansion vessel - 6 litres

Available in the following models:

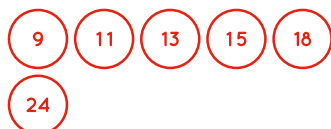

Model	Gas type	Code	Heat input		L x H x P mm	Gross weight kg
			Nominal (Qn) kW	Nominal DHW kW		
CTFS 9	NATURAL GAS	CNEXX2CG09	10,4	20,0	400x700x250	25,00
	LPG	CNEXX3CG09				
CTFS 11	NATURAL GAS	CNEXX2CG11	12,3	20,0	400x700x250	25,00
	LPG	CNEXX3CG11				
CTFS 13	NATURAL GAS	CNEXX2CG13	14,2	20,0	400x700x250	25,00
	LPG	CNEXX3CG13				
CTFS 15	NATURAL GAS	CNEXX2CG15	16,4	20,0	400x700x250	25,00
	LPG	CNEXX3CG15				
CTFS 18	NATURAL GAS	CNEXX2CG18	20,0	20,0	400x700x250	25,50
	LPG	CNEXX3CG18				
CTFS 24	NATURAL GAS	CNEXX2CG24	25,5	25,5	400x700x250	25,50
	LPG	CNEXX3CG24				

DIMENSIONS AND CONNECTION CENTRE DISTANCES

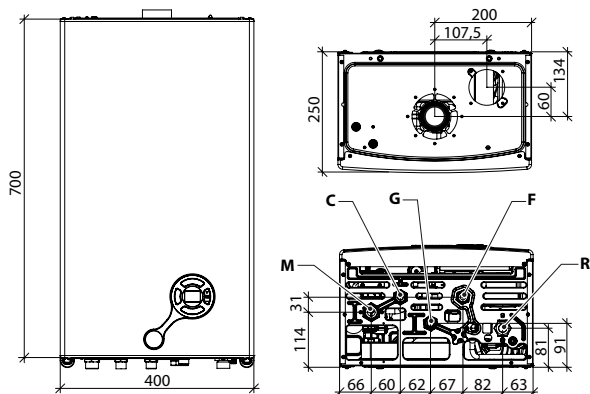

M CH system flow (3/4")
C DHW outlet (1 1/2")
G Gas inlet (1/2")

F Cold water inlet (1/2")
R CH system return (3/4")





Technical specifications	um	CTFS 9	CTFS 11	CTFS 13	CTFS 15	CTFS 18	CTFS 24
Nominal heat input (Qn)	kW	10,4	12,3	14,2	16,4	20,0	25,5
Nominal heat output (80-60°C) (Pn)	kW	9,3	11,1	13,0	15,1	18,6	23,3
Reduced heat input (Qr)	kW	7,0	7,0	7,0	7,0	7,0	11,5
Useful efficiency at nominal input (80-60°C)	%	89,2	90,2	91,2	91,8	93,2	91,2
Useful efficiency at 30% (47°C return)	%	86,2	86,9	87,6	87,7	88,2	87,4
Heating expansion vessel capacity	l	6	6	6	6	6	6
DHW nominal heat input	kW	20,0	20,0	20,0	20,0	20,0	25,5
Specific DHW flow ΔT=30K	l/min	9,5	9,5	9,5	9,5	9,5	11,7
NOx emission class	-	3	3	3	3	3	3
Electric protection rating	IP	X4D	X4D	X4D	X4D	X4D	X4D

Item	Description	Code	Item	Description	Code
	Compact wall pipe cover	0COPETUB00		Basic hydraulic kit	0KITIDBA29
	Remote control, ErP V class (118x85x32 mm)	0CREMOTO04		Tap kit with filter KC-KRB-CT-RBT	0KITRUBI05
	Coaxial kit D60/100 L=1m (for boiler TFS)	0KITCONC00		Coaxial flue kit	0SDOPPIA13
	Flow - return cold water 90° taps kit	0KITIDBA11		External probe (60x45x31 mm)	0SONDAES01
	Plus hydr. kit for basic compact unit	0KITIDBA14	Accessories supplied as standard		
	External probe (60x45x31 mm)	0SONDAES01		Ambient temperature probe	

