



DELFI Monothermal



IST 04 C 404 - 01

INSTALLATION, USE AND MAINTENANCE



CE

BRAND NAME



EN

Translation of the original instructions (in Italian)

Dear Sirs,

thank You for choosing and buying one of our products. Please read these instructions carefully in order to properly install, operate, and maintain the product.



WARNING

- **We inform users that:**
 - **Boilers shall be installed by an authorised company under the requirements set forth by the prevailing rules, in full compliance with the prevailing regulations and standards.**
 - **Anyone entrusting installation to an unqualified installer will be subject to administrative sanctions.**
 - **Boilers must be maintained by qualified personnel only, under the requirements set forth by the prevailing rules.**
-



WARNING

In existing buildings, this natural draught boiler must be connected only to flue pipes shared by several houses to vent the combustion residues outside the premises inside which boiler is installed.

Boiler takes the air necessary to combustion directly from the installation premises and features a wind-proof flue.

Due to a lower efficiency, any other use of this boiler must be avoided as it would result in a higher energy consumption and higher operating costs.

We hereby inform you that certain models, versions and/or accessories relevant to the products this manual refers to, might not be available in some countries.

Therefore, it is recommended to contact the manufacturer or the importer in order to get the necessary information about the actual availability of such models, versions and/or accessories.

The manufacturer reserves the right to modify the products and/or its components as deemed necessary, in any moment and without prior notice.

This instruction manual is available in two languages, Italian and English, without prejudice to the prevalence of Italian language in case of differences in translation and/or dispute on construction of the text.

General notes for installing and maintenance technicians, and users

This instruction manual is an integral and essential part of the product. It shall be supplied by the installer to the user who shall keep it carefully to consult it whenever necessary.

This document shall be supplied together with the equipment in case the latter is sold or transferred to others.



DANGER

This equipment has been manufactured to be connected to a room heating system and to a DHW distribution system.

Any other use shall be considered unsuitable and dangerous for people, animals, and/or property.

The equipment shall be installed in compliance with the prevailing standards and in accordance with the manufacturer's instructions specified in this manual: the manufacturer will not be held responsible for injuries to people and animals and/or damages to property resulting from an incorrect installation.

Damage and/or injury caused by incorrect installation or use and/or damage and/or injury due to non-observance of the manufacturer's instructions shall release the manufacturer from any and all contractual and extra-contractual liability.

Before installing the boiler, check that the technical data correspond to the requirements for its correct use in the system.

Check that the boiler is intact and it has not been damaged during transport and handling. Do not install equipment which is clearly damaged and/or faulty.

Do not obstruct the air intake openings.

Only original accessories or optional kits (including the electric ones) are to be installed.

Properly dispose of the packaging as all the materials can be recycled. The packaging must therefore be sent to specific waste management sites.

After removing the packaging, make sure that its elements (clips, plastic bags, foam polystyrene etc.) are not left within the reach of children as they are potential hazard sources.

In the event of failure and/or faulty functioning, switch off the boiler. Do not attempt to make repairs: contact qualified technicians.

Original parts must be used for all repairs to the boiler.

Non-observance of the above requirements may affect the safety of the boilers and endanger people, animals and/or property.

This appliance is not intended for use by persons (including children) with reduced physical, sensory or mental capabilities, or lack of experience and knowledge, unless they have been given supervision or instruction concerning use of the appliance by a person responsible for their safety.

Children should be supervised to ensure that they do not play with the appliance.



WARNING

The boiler must be serviced periodically as indicated in the relevant section of this manual.

Appropriate boiler maintenance ensures efficient operation, environment preservation, and safety for people, animals and objects.

Incorrect and irregular maintenance can be a source of danger for people, animals and property.

The user is strongly advised to have the system serviced and repaired by qualified personnel, satisfying all prevailing law requirements, and trained to properly carry out these operations.

In the event of long periods of inactivity of the boiler, disconnect it from the electrical power mains and close the gas cock. **The electronic antifreeze function will not be operative with the device disconnected from the electric power supply and gas cock closed.**

Should there be a risk of freezing, add antifreeze: it is not advisable to drain the system as this may result in damage; use specific anti-freeze products suitable for multi-metal heating systems.



DANGER

With gas fired boilers, take the following measures if you smell gas:

- **Do not turn on or off electric switches and do not turn on electric appliances.**
- **Do not ignite flames and do not smoke.**
- **Close the main gas cock.**
- **Open doors and windows.**
- **Contact a Service Centre, a qualified installer or the gas supply company.**

Never use a flame to locate a gas leak.

The boiler is designed for installation in the countries indicated on the technical data plate: installation in any other country may be a source of danger for people, animals and/or property.

The manufacturer will bear no contractual and tortious liability for failure to comply with all the instructions above.

1.	<i>Instructions for the user</i>	8
1.1	<i>Control panel</i>	8
1.2	<i>Interpreting boiler status from display indications</i>	10
1.3	<i>Boiler operation</i>	11
1.4	<i>Boiler shut-down</i>	14
1.5	<i>Maintenance</i>	16
1.6	<i>Notes for the user</i>	16
2.	<i>Technical features and dimensions</i>	17
2.1	<i>Technical features</i>	17
2.2	<i>Dimensions</i>	19
2.3	<i>Boiler layouts</i>	20
2.4	<i>Operating data</i>	21
2.5	<i>General characteristics</i>	21
2.6	<i>ERP and Labelling data</i>	22
3.	<i>Instructions for the installer</i>	23
3.1	<i>Installation standards</i>	23
3.2	<i>Choosing where to install the boiler</i>	23
3.3	<i>Positioning the boiler</i>	24
3.4	<i>Installing the boiler</i>	25
3.5	<i>Air intake and flue gas venting system</i>	25
3.6	<i>Checking combustion efficiency</i>	28
3.7	<i>Connection to gas mains</i>	28
3.8	<i>Hydraulic connections</i>	29
3.9	<i>Connection to electrical mains</i>	29
3.10	<i>Connection to ambient thermostat (optional)</i>	30
3.11	<i>Installation and operation with Open Therm Remote Control (optional)</i>	30
3.12	<i>TSP parameters</i>	31
3.13	<i>Filling the system</i>	35
3.14	<i>Starting up the boiler</i>	36
3.15	<i>Available head</i>	36
3.16	<i>Wiring diagram</i>	37
3.17	<i>Adaptation to other gas types and burner adjustment</i>	39
4.	<i>Testing the boiler</i>	41
4.1	<i>Preliminary checks</i>	41
4.2	<i>Switching on and switching off</i>	41
5.	<i>Maintenance</i>	42
5.1	<i>Maintenance schedule</i>	42
5.2	<i>Combustion analysis</i>	43
6.	<i>Decommissioning, disassembly and disposal</i>	43
7.	<i>Malfunctions, possible causes and solutions</i>	44
7.1	<i>Troubleshooting</i>	44

Fig. 1 Control panel	8
Fig. 2 Filler cock	15
Fig. 3 Model CTN dimensions	19
Fig. 4 Boiler layout CTN	20
Fig. 5 Paper template	24
Fig. 6 Connections to the chimney of open chamber models	27
Fig. 7 Dimensions for connection to the flue gas system of the open chamber models	27
Fig. 8 Connection to gas mains	28
Fig. 9 Thermoregulation curves	34
Fig. 10 Available head	36
Fig. 11 Wiring diagram CTN	37
Fig. 12 SIT 845	40

Tab. 1 Adjustment specifications	21
Tab. 2 General specifications	21
Tab. 3 CTN 24 combustion specifications	22
Tab. 4 ERP and Labelling data	22
Tab. 5 Limits to be set for TSP parameters and default values in relation to boiler type (TSP0) - I	31
Tab. 6 Limits to be set for TSP parameters and default values in relation to boiler type (TSP0) - II	32
Tab. 7 Relationship between "Temperature and Nominal resistance" for temperature probes	38

1. Instructions for the user

1.1 Control panel

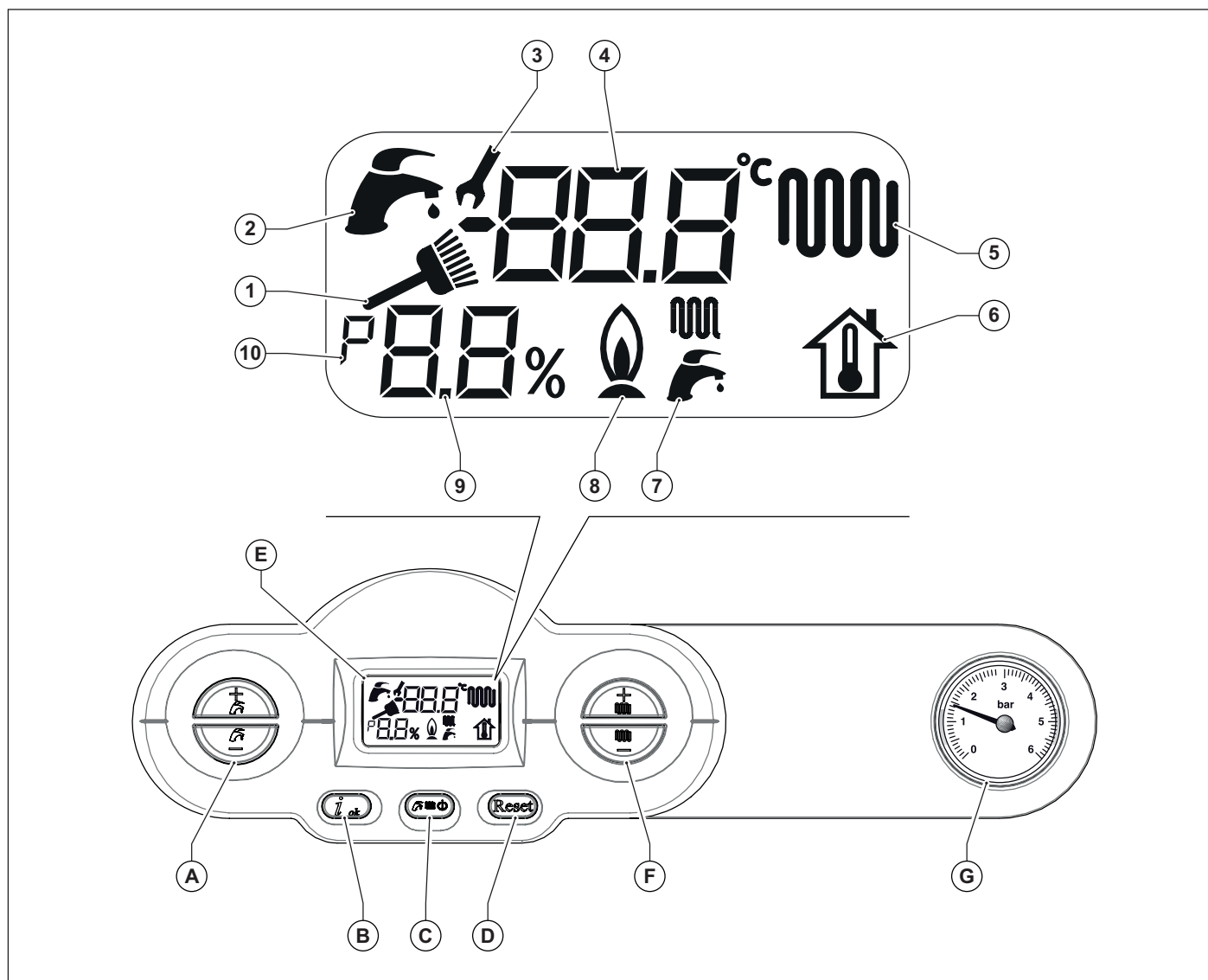

Fig. 1 Control panel

- A. DHW setting (+/- **DHW**).
- B. Parameter confirmation and information request.
- C. Operating status selection.
- D. Alarm reset and back to the starting page during parameter selection.
- E. LCD display.
- F. CH water temperature (+/- **CH**) and parameter settings.
- G. Heating system water pressure gauge.

Ref.	Description	Steady on	Flashing
1	Flue cleaning function indicator (for the installer)	Flue cleaning function active.	Indicates that you are accessing the flue cleaning function.
2	DHW indicator	Boiler is in DHW mode.	Displaying of the DHW temperature set-point.
3	Parameter editing indicator	During parameter editing, the wrench symbol stays on until the set datum is confirmed.	When edited parameter value is confirmed.
4	Alphanumeric indicator	Temperature, parameter values and fault indication.	Not used.
5	Central heating indicator	Boiler is in heating mode.	Displaying of the heating temperature set-point.
6	Fictitious ambient temperature indicator	Not used.	Displaying of the fictitious ambient temperature set-point.
7	Boiler status indicator	DHW and/or heating function active.	Not used.
8	Flame lighting indicator	Lit flame indication.	Not used.
9	Parameter code indicator	Displaying of the number of parameters or of the burner power percentage.	Not used.
10	Parameter indicator	Indication of "parameter" inside the parameter menu.	Not used.

1.2 Interpreting boiler status from display indications

1.2.1 Normal operation

Boiler in STANDBY mode



Boiler in SUMMER mode
No active function
Flow temperature displayed



Boiler in WINTER mode
No active function
Flow temperature displayed



Boiler in CENTRAL HEATING ONLY mode
No active function
Flow temperature displayed



Boiler in SUMMER mode
Domestic hot water withdrawal
DHW temperature displayed

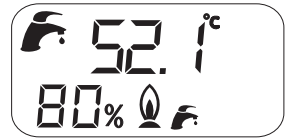

Boiler in WINTER mode
Domestic hot water withdrawal
DHW temperature displayed

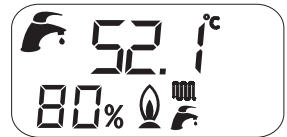

Boiler in WINTER mode
CH function active
Flow temperature displayed

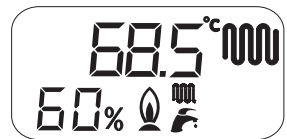

Boiler in CENTRAL HEATING ONLY mode
CH function active
Flow temperature displayed

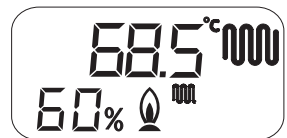

1.2.2 Malfunction

To identify any malfunctions, refer to paragraph *Troubleshooting* on page 44.

1.3 Boiler operation

1.3.1 Switching on



DANGER

It is presumed that the boiler has been installed by a qualified installer, it has been commissioned and is ready to operate correctly.

- Open the gas shut-off cock.
- Turn the master switch installed ahead of the boiler to ON.
- The display turns on and indicates the function currently active (see *Interpreting boiler status from display indications* on page 10).
- Select the boiler operating mode: OFF/SUMMER/WINTER/CH ONLY (see button (C) in Fig. 1 Control panel on page 8).
- Set desired CH temperature (see *CH function* on page 11).
- Set desired DHW temperature (see *DHW function* on page 12).
- Set the desired room temperature on the ambient thermostat inside the home (if installed).



WARNING

After a prolonged period with the boiler not in use, and with LPG fired boilers in particular, some starting difficulty may be encountered.

Before starting the boiler switch on another gas powered device (e.g. kitchen range).

Beware that even by following this procedure, the boiler might still experience some starting difficulties and shut down once or twice. Press the "RESET" button to restore boiler operation.

1.3.2 Selecting the operating mode

To select the boiler operation mode press **C** Operating mode selection.

Whenever button is pressed, the following modes are enabled in sequence: "SUMMER", "WINTER", "CH ONLY", "OFF".

"SUMMER" operating status

When the "SUMMER" mode is enabled, only the DHW production function is active.

"WINTER" operating status

When the "WINTER" mode is enabled, both DHW and CH functions are active.

"CH ONLY" operating status

When the "CH ONLY" mode is enabled, only the heating water production function is active.

"OFF" operating status

When the "OFF" mode is enabled, no function is active.

1.3.3 CH function

To set the heating water temperature, press +/- **CH** buttons.

The CH temperature setting range is from +35 °C to +78 °C.

During temperature setting, the  symbol flashes on the screen and the CH current temperature setting is displayed.

When the CH system requests heat from the boiler, the LCD displays the CH symbol  and the current CH flow water temperature.

The waiting time between one boiler ignition and the following one, used to prevent boiler frequent turning on and off, ranges between 0 and 10 minutes (default value: 4 minutes), and can be edited with the **P11** parameter.

Should water temperature in the system fall below set minimum value, between 35°C and 78°C (default value 40°C) to be edited with the **P27** parameter, the waiting time is reset and the boiler re-ignites.

The burner ON symbol  shows while the burner is operating.

1.3.4 DHW function

Boiler electronics always gives priority to DHW over CH supply.

To set the domestic hot water temperature, press **DHW +/-** buttons.

The DHW temperature setting range is from +35 °C to +57 °C.

During temperature setting, the  symbol flashes on the screen and the DHW current temperature setting is displayed.

The burner ON symbol  shows while the burner is operating.

1.3.5 Freeze protection function

This boiler is fitted with a freeze protection system, which works when the following functions are activated: OFF/SUMMER/WINTER/CH ONLY.



DANGER

The freeze protection function only protects the boiler, not the whole heating system.

The central heating system can be effectively protected against icing by using specific anti-freeze products that are suitable for multi-metal systems.



WARNING

Do not use anti-freeze products for car engines, and check the effectiveness of the product used over time.

In case burner cannot be ignited due to the lack of gas, the freeze protection functions are anyway enabled through the circulation pumps.

1.3.5.1 Flow freeze protection function

When the heating water temperature sensor detects a water temperature of +5 °C, the boiler switches on and stays on at its minimum heat output until the temperature reaches +30 °C or 15 minutes have elapsed.

The pump continues to operate even if the boiler shuts down.

1.3.5.2 DHW plate exchanger freeze protection function

When the DHW temperature sensor detects a water temperature of +5°C, the boiler switches on and stays on at its minimum heat output until the DHW temperature reaches +10°C or 15 minutes have elapsed (the deviating valve is in the DHW position).

During the DHW freeze protection operation the temperature detected by the flow probe is constantly checked, and in case it reaches +60 °C the burner is switched off.

The burner is switched on again if the operation request in anti-freeze mode is still present and the flow temperature is below +60°C.

The pump continues to operate even if the boiler shuts down.

1.3.6 Anti-seize function

If the boiler remains inactive and connected to the power mains, the circulation pump and the deviating valve (if any) will be shortly enabled every 24 hours so as to avoid any shut-down.

The same applies to the relay which can be freely programmed whenever this latter is used to power a recirculation pump or a deviating valve.

1.3.7 Timed post-circulation function

After each central heating, DHW or freeze protection request, the pump continues to be powered for 30 seconds.

If a new central heating, DHW or freeze protection request is received during this period, the post-circulation function is cancelled in order to fulfil the request.

1.3.8 Operation with external probe (optional)

Boiler can be connected to a probe measuring the external temperature (optional - not compulsory, supplied by the manufacturer).

Once the external temperature value is known, the boiler will automatically adjust the heating water temperature: increasing it as the external temperature decreases and decreasing it as the external temperature increases. This will both improve room comfort and reduce fuel consumption. The maximum temperature is respected all the same.

This boiler operating mode is called "sliding temperature operation".

Heating water temperature varies based on a programme written inside boiler electronic microprocessor.

When working with an external probe, the **CH +/-** buttons are no longer used to set heating water temperature, but to edit fictitious ambient temperature, namely the desired theoretical temperature.

During temperature setting, the fictitious ambient temperature  symbol flashes on the display and the value being set is shown.

For optimal curve adjustment, a position close to +20 °C is recommended.

For further details on "cruising temperature operation", refer to paragraph *Installation of the (optional) external probe and sliding temperature operation* on page 33.



WARNING

Only original external temperature probes supplied by the manufacturer must be used.

The use of non-original external probes, not supplied by the manufacturer, may affect the operation of the external probe itself and of the boiler.

1.3.9 Operation with (optional) remote control

The boiler can also be connected to a Remote Control (optional - not compulsory, supplied by the manufacturer) so as to manage several boiler parameters, such as:

- boiler status selection.
- ambient temperature selection.
- CH system water temperature selection.
- DHW temperature selection.
- CH system activation time programming.
- boiler diagnostics display.
- boiler reset and other parameters.

To connect the Remote Control, see *Installation and operation with Open Therm Remote Control (optional)* on page 30.



WARNING

Only use original Remote Control Units supplied by the manufacturer.

The use of non-original remote controls, not supplied by the manufacturer, may affect Remote Control and boiler operation.

1.4 Boiler shut-down

The boiler shuts down automatically if a malfunction occurs.

To determine the possible causes of malfunction (see *Troubleshooting* on page 44).

Below is a list of shut-down types and the procedure to follow in each case.

1.4.1 Burner shut-down

Fault code **E01** is displayed flashing on the display in the event of burner shut-down due to missing flame.

If this happens, proceed as follows:

- check that the gas cock is open and light a kitchen gas ring for example to check the gas supply;
- once having checked if the fuel is available, press the **Reset** button to restore burner operation: if, after two starting attempts, the boiler still fails to start and enters the shut-down mode again, contact a service centre or qualified personnel for maintenance.



WARNING

If the burner shuts down frequently, there is a recurring malfunction, so contact a service centre or a qualified service engineer.

1.4.2 Shut-down due to overheating

Fault code **E02** is shown on the LCD display in the event of flow water temperature overheating. Contact a service centre or a qualified service engineer to carry out the maintenance.

1.4.3 Shut-down due to incorrect air/flue gas system draught

The boiler is equipped with a safety device for flue gas exhaustion check.

Should an air/flue gas system malfunction occur, the control device will shut-down the boiler by interrupting the gas supply to the boiler and the LCD will display the **E03** code.

To resume the operation press **Reset** (see Fig. 1 Control panel on page 8).

In case of repeated stops, it is necessary to have the boiler and the air intake/flue gas venting ducts checked by a service centre or a qualified service engineer.

1.4.4 Shut-down due to low water pressure

Fault code **E04** is displayed on the LCD display in the event of shut-down triggered by the water pressure switch.

Fill the system by working on filler cock (A) (see Fig. 2 Filler cock).

Water pressure must be 1÷1.3 bars while the boiler is cold.

In order to restore water pressure, proceed as follows:

- Turn the filler cock anticlockwise to allow water to enter the boiler;
- Keep the filler cock open until the pressure gauge shows a value of 1÷1.3 bar;
- Turn cock clockwise to close it.

Should boiler shuts down frequently occur it means there is boiler malfunction in progress. Contact qualified personnel or an authorised service centre for maintenance.



DANGER

Make sure you close filler cock (A) carefully after filling procedure is completed.

If you do not, when the pressure increases, the safety valve may activate and discharge water.

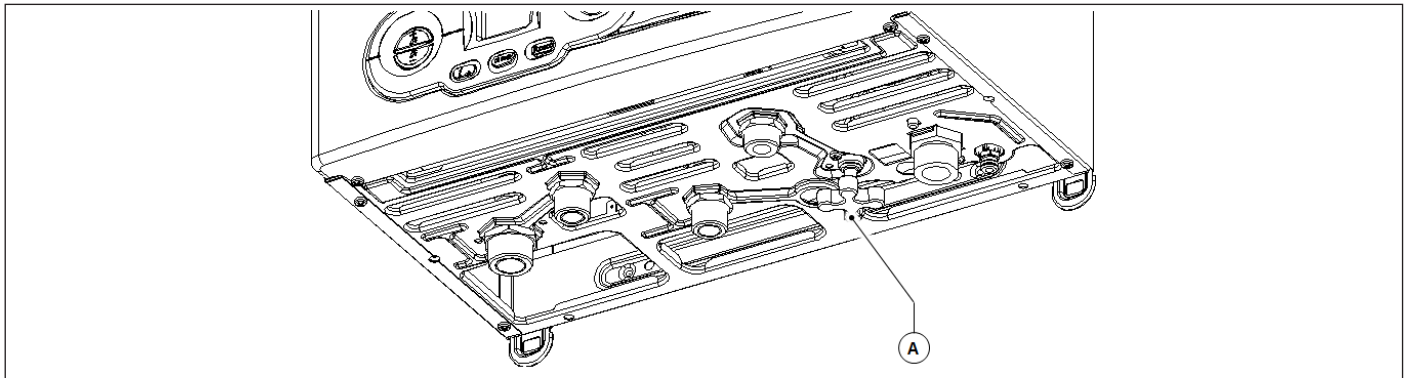

Fig. 2 Filler cock

1.4.5 Alarm due to temperature probe malfunction

The following fault codes are shown on the display in the event of burner shut-down due to a temperature probe fault:

- **E05** for the CH probe: in this case the boiler does not work.
- **E06** for the DHW probe; in this case, the boiler functions in central heating mode only, and the DHW function is disabled.



WARNING

In any case, contact a service centre or qualified personnel for maintenance.

1.4.6 Alarm due to (optional) Remote Control connection malfunction

The boiler recognises whether or not there is a Remote Control (optional, not compulsory).

If the boiler does not receive information from the Remote Control after the Remote Control itself is connected, the boiler attempts to re-establish communication for 60 seconds, after which the fault code **E31** is shown on the remote control display.

The boiler will continue to operate according to the settings on the touch screen and ignore the Remote Control settings.



WARNING

Contact a service centre or a qualified service engineer to carry out the maintenance.

The remote control can indicate faults or shutdown conditions and can also restore boiler operation after shutdown up to a maximum of 3 times in a 24 hour period.

If the maximum number of attempts is reached, fault code **E99** is shown on the boiler display.

To reset error **E99**, disconnect and re-connect again boiler from/to power mains.

1.5 Maintenance



WARNING

The boiler must be serviced periodically as indicated in the relevant section of this manual.

Appropriate boiler maintenance ensures efficient operation, environment preservation, and safety for people, animals and objects.

Boilers must be maintained by qualified personnel only, under the requirements set forth by the prevailing rules.

1.6 Notes for the user



WARNING

The user may only access parts of the boiler that can be reached without using special equipment or tools. The user is not authorised to remove the boiler casing or to operate on any internal parts.

No one, including qualified personnel, is authorised to modify the boiler.

The manufacturer shall not be held responsible in case of damage to people, animals, or property due to failure to follow the above mentioned instructions.

If the boiler remains inactive and the power supply is switched off for a long time, it may be necessary to reset the pump.

This involves removing the casing and accessing internal parts, so it must only be carried out by suitably qualified personnel.

Pump failure can be avoided by adding to the water filming additives suitable for multi-metal systems.

2. Technical features and dimensions

2.1 Technical features

The boiler is equipped with an integrated gas atmospheric burner. The following models are available:

- **CTN** open chamber, natural draught boiler with electronic ignition for heating and instantaneous DHW supply.

The following power rates are available:

- **CTN 24:** with heat input of 24.5 kW

All models are equipped with electronic ignition and ionisation flame sensing device.

The boilers meet local applicable Directives enforced in the country of destination, which are stated on their rating plate.

Installation in any other country may be a source of danger for people, animals and property.

The key technical features of the boilers are listed below.

2.1.1 Manufacturing characteristics

- IPX4D electrically protected control panel.
- Integrated, modulating electronic safety board.
- Electronic ignition and ionisation flame detection device.
- Stainless steel, atmospheric burner that can run on several gases.
- Mono-thermal, high performance, copper heat exchanger.
- Twin shutter modulating gas valve.
- High-efficiency CH circulation pump with built-in air purging device.
- Safety pressure switch, preventing low water pressure operation.
- Flue gas thermostat
- Integrated, automatic by-pass.
- 7 litre expansion vessel.
- System water discharge tap.
- Heating flow water temperature probes.
- Stainless steel plate heat exchanger for DHW production.
- Motorised deviating valve.
- DHW priority flow switch.
- 10 litre/min DHW flow-limiting device.
- Domestic hot water temperature probe.
- System filler cock.

2.1.2 User interface

- Liquid crystal LCD interface showing the boiler operating status: OFF, SUMMER, WINTER and CH ONLY.
- CH water temperature setting buttons: 35-78 °C.
- DHW temperature setting buttons: 35-57 °C.
- System water pressure gauge.

2.1.3 Operating features

- Electronic flame modulation in CH mode, with timed rising ramp.
- Electronic flame modulation in DHW mode.
- Flow freeze protection function: ON 5°C; OFF 30°C or after 15 minutes of operation if CH temperature > 5 °C.
- DHW freeze protection function (CTFS): ON 5°C; OFF 10 °C or after 15 minutes of operation if DHW temperature > 5 °C.
- Timer-controlled flue cleaning function: 15 minutes.
- CH Maximum heat input parameter adjustment.
- Ignition heat input adjustment parameter.
- Ignition flame propagation function.
- CH thermostat timer: 240 seconds (adjustable).
- Heating pump post-circulation function in CH, freeze protection and flue cleaning modes: 30 seconds (adjustable).
- DHW post-circulation function: 30 seconds (adjustable).
- Post-circulation function for heating temperature > 78 °C: 30 seconds.
- Circulation pump and deviating valve anti shut-down function: 30 seconds of operation after 24 hours of inactivity.
- Ready for connection to an (optional) ambient thermostat.
- Ready for operation with an external probe (optional, supplied by the manufacturer).
- Ready for operation with an OpenTherm remote control (optional, supplied by the manufacturer).
- Anti-water hammer function: can be set from 0 to 3 seconds.
- DHW function priority.

2.2 Dimensions

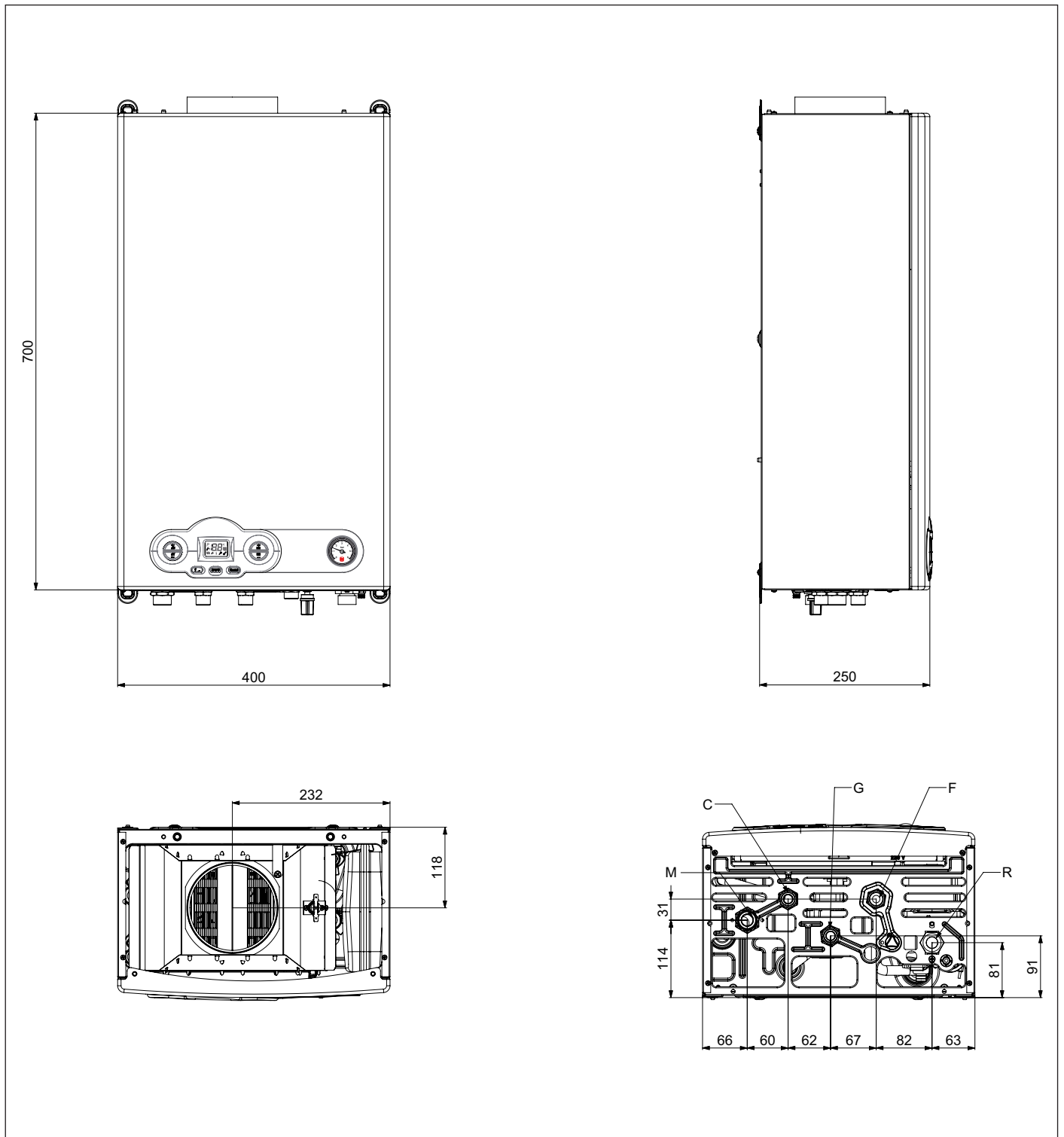

Fig. 3 Model CTN dimensions

- M** CH system flow - 3/4"
- C** DHW outlet - 1/2"
- G** Gas inlet - 1/2"
- F** Cold water inlet - 1/2"
- R** CH system return - 3/4"

2.3 Boiler layouts

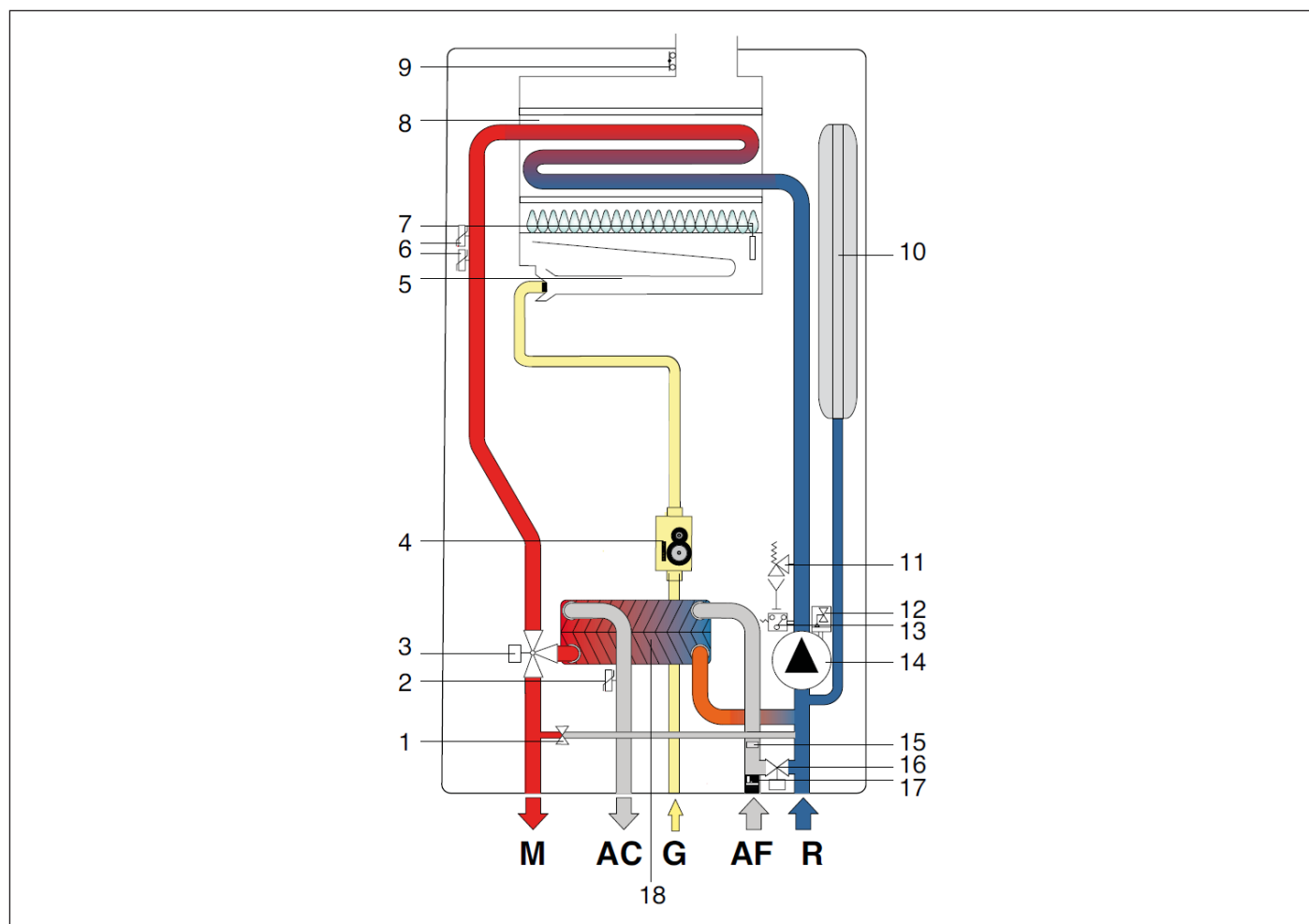

Fig. 4 Boiler layout CTN

1. Automatic by-pass
2. DHW temperature probe
3. Motorised 3-way valve
4. Modulating gas valve
5. Burner
6. CH temperature double probe
7. Ignition/detection electrode
8. Mono-thermal heat exchanger
9. Flue gas thermostat
10. Expansion tank
11. 3-bar safety valve
12. Air-purging device
13. Minimum pressure switch
14. Circulation pump
15. 10 l/min flow-limiting device
16. Filler cock
17. Cold water flow switch with filter
18. Secondary plate exchanger

- M** CH system flow
- AC** DHW outlet
- G** Gas inlet
- AF** Cold water inlet
- R** CH system return

2.4 Operating data

Burner pressures reported in the following page must be verified after the boiler has been operating for 3 minutes.

Gas category: II2H3+

Fuel	Gas mains pressure [mbar]	Nozzle [mm]	Min pressure at the burner [mbar]	Max pressure at the burner [mbar]
Natural gas G20	20	1,27	3,2	12,4
Butane gas G30	29	0,77	7,2	27,1
Propane Gas G31	37	0,77	9,2	35,0

Tab. 1 Adjustment specifications

2.5 General characteristics

Description	um	CTN 24
Burner nozzles	no.	11
Nominal heat input	kW	24,5
Minimum heat input	kW	12,0
Max heat output	kW	22,07
Minimum heat output	kW	10,46
Minimum CH system pressure	bar	0,5
Maximum CH system pressure	bar	3,0
DHW circuit min. pressure	bar	0,5
DHW circuit max. pressure	bar	8,0
DHW specific flow rate ($\Delta T=25K$)	l/min	12,7
DHW specific flow rate ($\Delta T=30 K$)	l/min	10,6
Electric power supply – voltage / frequency	V - Hz	230 - 50
Power mains supply fuse	A	3,15
Maximum power consumption	W	57
Pump absorption	W	41
Electric protection rating	IP	X4D
Net weight	kg	23,0
Natural gas consumption (*)	cu. m/h	2,59
Butane gas consumption	kg/h	1,93
Propane gas consumption	kg/h	1,90
Maximum CH working temperature	°C	83
Maximum DHW working temperature	°C	62
Total capacity of expansion vessel	l	7
Maximum recommended system capacity (**)	l	100

Tab. 2 General specifications

(*) Value referred to 15 °C - 1013 mbar

(**) Maximum water temperature 83°C, expansion vessel pressure 1 bar

Description	um	Max. output	Min. output	30% load
Heat loss from the boiler casing	%	3,04	4,24	-
Flue system heat loss with burner on	%	6,86	8,56	-
Flue system mass capacity	g/s	16,72	14,98	-
Flue temp. – air temp.	°C	83	62	-
CO2 value (methane/butane/propane)	%	5.7 / 6.7 / 7.3	3.0 / 3.5 / 3.7	-
Maximum heat output efficiency rating	%	90,1	87,15	88,45
NOx emission class	-		2	

Tab. 3 CTN 24 combustion specifications

2.6 ERP and Labelling data

Model(s): DELFIS CTN 24	
Condensing boiler: no	
Low-temperature (**): boiler: no	
B1 boiler: yes	
Cogeneration space heater: no	If yes, equipped with a supplementary heater: -
Combination heater: yes	

Item	Symbol	Value	Unit	Item	Symbol	Value	Unit
Rated heat output	P_{rated}	22	kW	Seasonal space heating energy efficiency	η_s	76	%
For boiler space heaters and boiler combination heaters: Useful heat output				For boiler space heaters and boiler combination heaters: Useful efficiency			
At rated heat output and high-temperature regime (*)	P_4	22,1	kW	At rated heat output and high-temperature regime (*)	η_4	81,1	%
At 30 % of rated heat output and low-temperature regime (**)	P_1	6,5	kW	At 30 % of rated heat output and low-temperature regime (**)	η_1	79,7	%
Auxiliary electricity consumption				Other items			
At full load	$e_{l_{max}}$	0,012	kW	Standby heat loss	P_{stby}	0,150	kW
At part load	$e_{l_{min}}$	0,011	kW	Ignition burner power consumption	P_{ign}	0,000	kW
In standby mode	P_{SB}	0,001	kW	Annual energy consumption	Q_{HE}	84	GJ
				Emissions of nitrogen oxides	NO_x	149	mg/kWh
				Sound power level, indoors	L_{WA}	52	dB(A)
For combination heaters:							
Declared load profile	XL			Water heating energy efficiency	η_{wh}	77	%
Daily electricity consumption	Q_{elec}	0,107	kWh	Daily fuel consumption	Q_{fuel}	24,650	kWh
Annual electricity consumption	AEC	23	kWh	Annual fuel consumption	AFC	18	GJ

Contact details: FONDITAL S.p.A. - Via Cerreto, 40 I-25079 VOBARNO (Brescia) Italia - Italy

(*) High-temperature regime means 60 °C return temperature at heater inlet and 80 °C feed temperature at heater outlet.

(**) Low temperature means for condensing boilers 30 °C, for low-temperature boilers 37 °C and for other heaters 50 °C return temperature (at heater inlet).

Seasonal space heating energy efficiency class	C
Water heating energy efficiency class	B

Tab. 4 ERP and Labelling data

3. Instructions for the installer

3.1 Installation standards

This boiler must be installed in compliance with the laws and standards in force in the country of installation, which are herein considered as entirely transcribed.

To find out about the gas category and technical specifications, refer to operation data and general features specified in the previous pages.



DANGER

**Accessories and spare parts for installation and service procedures are to be supplied by the Manufacturer.
Should non original accessories and spare parts be employed, boiler proper performance is not guaranteed.**

3.1.1 Packaging

Boiler is shipped in a sturdy cardboard box.

Remove boiler from cardboard box and check its integrity.

The packing materials can be recycled. Disposal must be managed via appropriate waste collection sites.

Keep packaging out of reach of children, as it may be dangerous.

The manufacturer shall not be held responsible in case of damage to people, animals, or property due to failure to follow the above mentioned instructions.

Packaging includes one plastic bag containing:

- boiler installation, use and maintenance manual;
- the template for mounting the boiler on a wall (see Fig. 5 Paper template).
- 2 screws and relevant wall blocks for fixing the boiler to the wall;

3.2 Choosing where to install the boiler

The following must be taken into account when choosing where to install the boiler:

- indications contained in paragraph *Air intake and flue gas venting system* on page [25](#) and its sub-paragraphs.
- check the wall for sturdiness, avoiding weak areas.
- do not install the boiler over appliances which may affect boiler operation (e.g. cookers, which produce steam and grease, washing machines etc.).
- Do not install natural draught boilers in locations with a corrosive or very dusty atmosphere, such as hairdresser salons, laundries etc., as this may severely reduce the lifespan of the components of the boiler.
- do not install boilers in locations with a corrosive or very dusty atmosphere, such as hairdresser salons, laundries etc., as this may severely reduce the lifespan of the components of the boiler.

3.3 Positioning the boiler

Each boiler is supplied with a paper template, found inside the packaging (see Fig. 5 Paper template).

The template allows you to ensure that the pipes connected to the CH system, the DHW system and the gas mains, and the air intake/flue gas venting ducts are all laid out correctly during the realisation of the water system and before installation of the boiler.

This template is made of heavy-duty paper and must be fixed, with the help of a level, onto the wall where the boiler is to be mounted.

The template provides all the indications required to drill the boiler mounting holes to the wall, procedure which is done using two screws and wall blocks.

The lower area of the template shows where to mark the exact point at which the couplings are to be positioned for boiler connection to the gas supply pipe, cold water mains supply pipe, hot water outlet, CH flow and return pipes.

The upper area of the template shows where flue gas ducts are to be positioned.



In the case of proximity with flammable walls and passages through walls, apply insulating material between the wall and the flue gas venting duct.

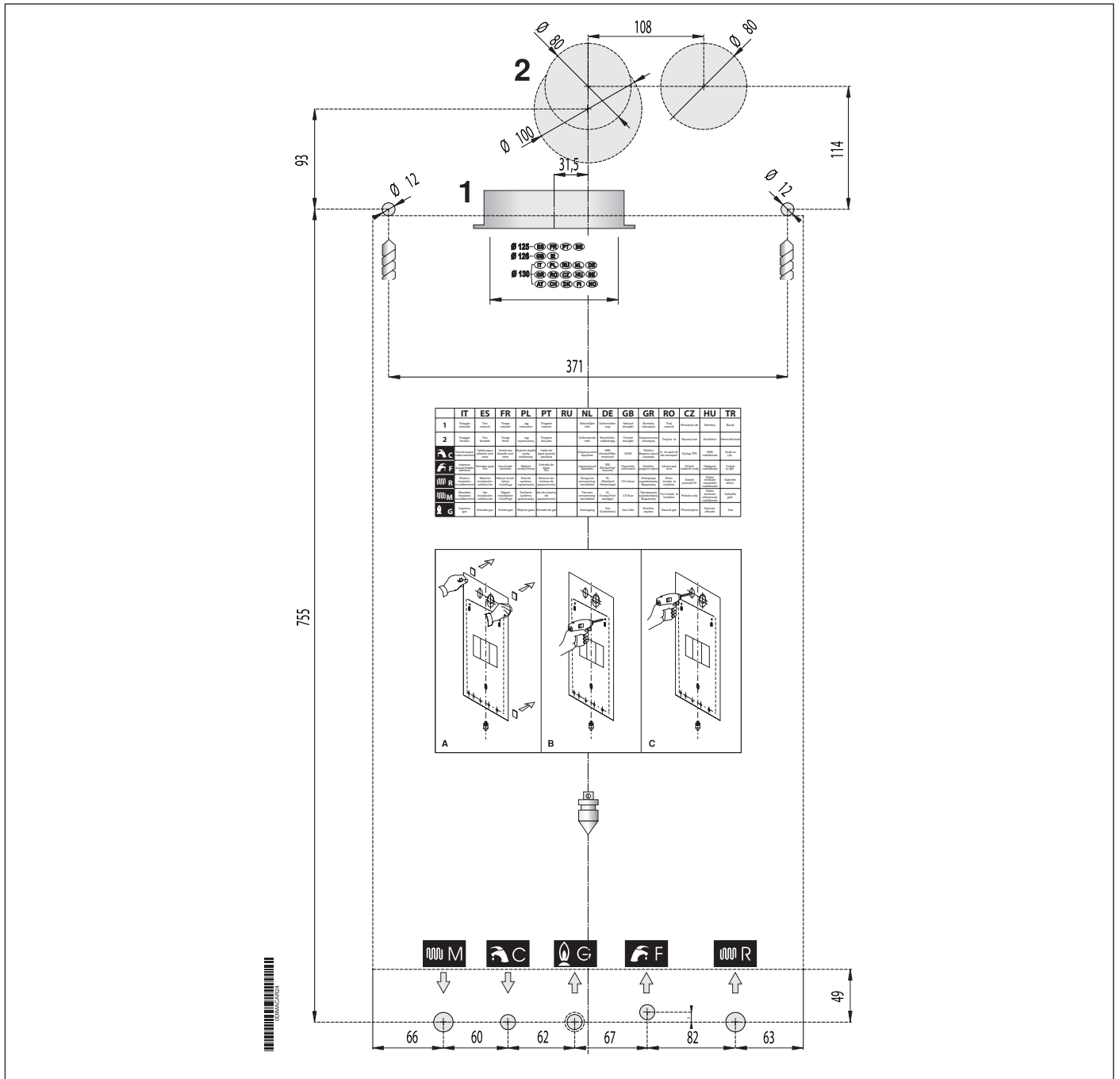

Fig. 5 Paper template

3.4 Installing the boiler



DANGER

Before connecting the boiler to CH and DHW networks, clean the pipes carefully.

Before commissioning a NEW system, clean it to remove any metal chips due to machining and welding, and any oil and grease that might negatively affect boiler operation or even damage it in case they get inside it.

Before commissioning a RECONDITIONED system (where radiators have been added, the boiler has been replaced, etc.) thoroughly clean it to remove any sludge and residues.

Clean the system using standard non acid products, available on the market.

Do not use solvents as they could damage system components.

Furthermore, in the central heating system (either new or reconditioned), it is always advisable to add to water a suitable percentage of corrosion protectants for multi-metal systems that will create a protective film onto all internal surfaces.

The manufacturer shall not be held responsible in case of damage to people, animals, or property due to failure to follow the above mentioned instructions.

In order to install the boiler proceed as follows:

- Affix the template to the wall.
- Check that 1 cm to the right and 1 cm to the left of the boiler is left for casing removal;
- Drill two 12 mm diameter holes in the wall for the wall plugs, insert the wall plugs supplied with the boiler and apply and tighten the screws;
- If necessary, provide holes in the wall to allow air intake and/or flue gas venting pipes to pass through it;
- Position the connections for the gas mains pipe **G**, the cold water inlet pipe **F**, the hot water outlet pipe **C**, and the central heating flow **M** and return pipes **R** as indicated at the bottom of the template;
- Hook the boiler to the previously fitted screws;
- Connect the boiler to the feed pipes (see *Hydraulic connections* on page 29);
- Connect the boiler to the air intake and flue gas venting system (see *Air intake and flue gas venting system* on page 25);
- connect power supply, ambient thermostat (when available) and other available accessories (refer to the following paragraphs).

3.5 Air intake and flue gas venting system

Flue gas discharge into the atmosphere and air intake/flue gas venting systems must comply with applicable laws and standards in the country of installation that are considered as fully transcribed herein.

In existing buildings, this natural draught boiler must be connected only to flue pipes shared by several houses to vent the combustion residues outside the premises inside which boiler is installed.

Boiler takes the air necessary to combustion directly from the installation premises and features a wind-proof flue.

Due to a lower efficiency, any other use of this boiler must be avoided as it would result in a higher energy consumption and higher operating costs.



DANGER

the boiler must be installed in a room that is compliant with the legislation and standards in force in the country of installation, which are herein considered as entirely transcribed.



DANGER

The boiler is equipped with a safety device for flue gas exhaustion check.

It is strictly forbidden to tamper with and/or prevent operation of such safety device.

Should an air/flue gas system malfunction occur, the device will shut-down the boiler by interrupting the gas supply to the boiler and the LCD will display the E03 code.

In this case it is necessary to have safety device, boiler and the air intake/flue gas venting ducts promptly checked by a service centre or a qualified service engineer.

In case of repeated stops, it is necessary to have safety device, boiler and the air intake/flue gas venting ducts checked by a service centre or a qualified service engineer.

After each operation on the safety device or the air suction/flue gas exhaust system, it is necessary to perform a functional test of the boiler.

In case it is necessary to replace the safety device use only original spare parts supplied by the Manufacturer.

The actual waiting time for the automatic reset of the combustion gas exhaust control device is equal to 10 minutes. To reset the device before this time it is necessary to press "Reset".



DANGER

Damage and/or injury caused by incorrect installation and/or incorrect use and/or unauthorized changes to the boiler and/or non-observance of the manufacturer's instructions and/or of the relative standards/laws in force in the country of installation, shall release the manufacturer from any and all liability.

Connection to the chimney

The chimney is indispensable for correct boiler operation; it must therefore comply with the following requirements:

- it must be made of waterproof material and be resistant to flue gas temperature and related condensate;
- it must have appropriate mechanical characteristics and low thermal conductivity;
- it must be perfectly sealed;
- it must be as vertical as possible and the roof terminal is to have a cap ensuring efficient and constant flue gas exhaustion;
- it must not be less wide than the boiler flue gas outlet diameter; squared or rectangular section chimneys must bear an internal section, 10% larger than the section connected to the boiler draught excluder device;
- starting from the boiler, the duct connecting to the chimney is to follow a vertical direction and must be long not less than twice its diameter before joining the chimney.

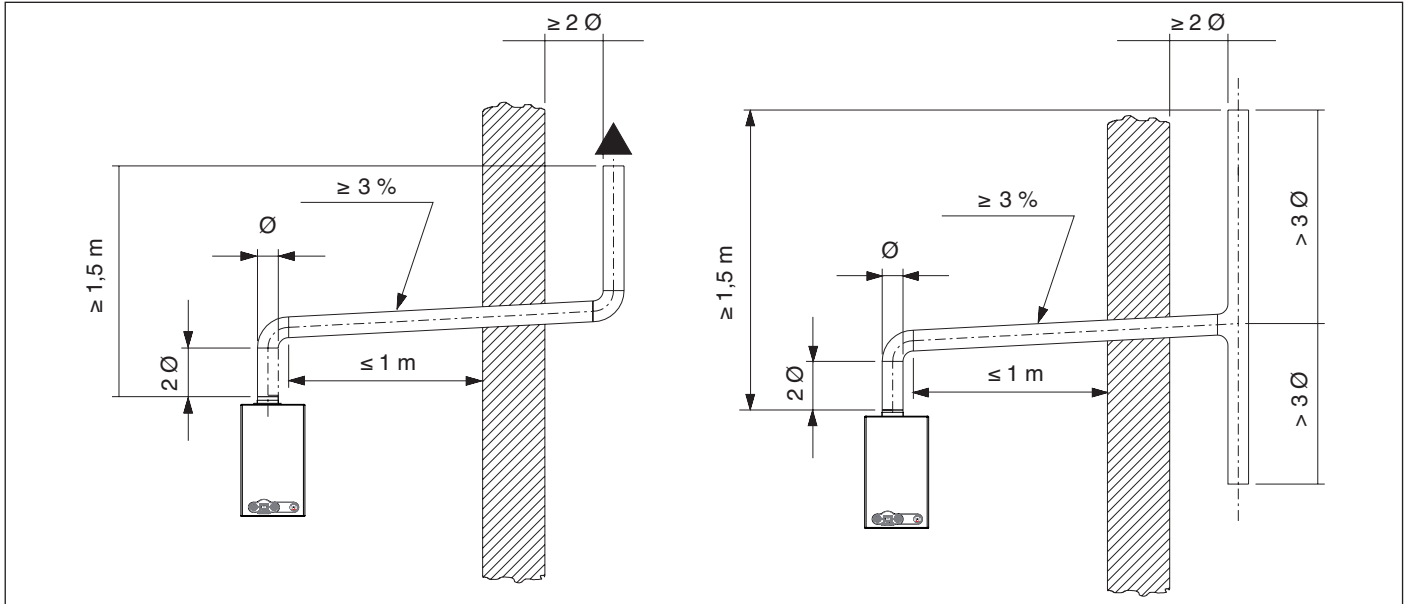

Fig. 6 Connections to the chimney of open chamber models

Direct emission into the atmosphere

Natural draught boilers can vent flue gas directly into the atmosphere via a duct which goes through the outside walls of the building and ends with an anti-wind gust device terminal.

The flue gas exhaust duct is to comply with the following requirements:

- its sub-horizontal part inside the building must be as short as possible (not longer than 1,000 mm);
- it is not to have more than 2 direction changes;
- it can host only one single boiler flue gas exhaust system;
- its section, which is passing through the wall is to be protected by a sheath duct; the part of the sheath duct facing the inside of the building is to be sealed, while the part facing outwards is to be left open;
- its end section, on which the draught terminal is to be installed, is to protrude from the wall of the building for a length of a least twice the diameter of the duct;
- the terminal must be no less than 1.5 meters above the connection for the flue gas venting duct on the boiler.

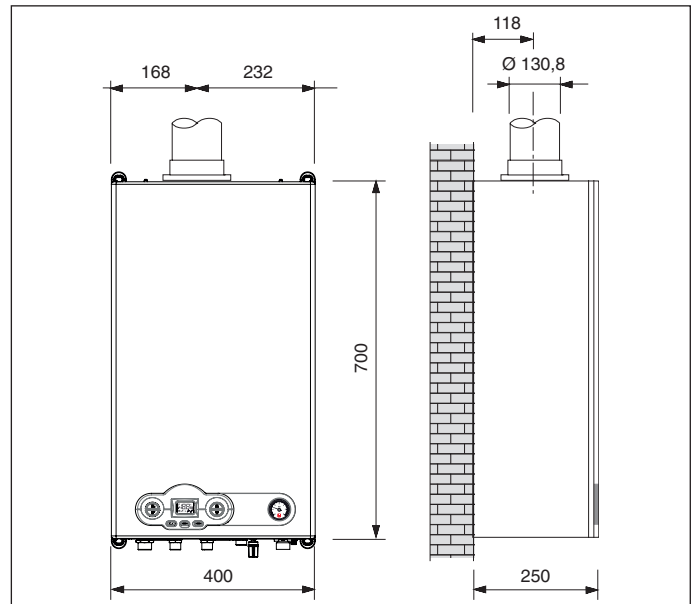



Fig. 7 Dimensions for connection to the flue gas system of the open chamber models

3.6 Checking combustion efficiency

3.6.1 Flue cleaning function

- The boiler features a flue cleaning function which must be used to measure combustion efficiency during operation and to adjust the burner.
- To activate the flue cleaning function, press and hold the buttons “Info” and “Reset” simultaneously for 5 seconds. The flow temperature and the  symbol are shown on the LCD.
- When the flue cleaning function is activated with the boiler in WINTER or SUMMER mode, the boiler performs the ignition sequence and then operates at a fixed power output predetermined by the parameter P7 (maximum CH output).
- To exit the flue cleaning mode, press “Reset” or wait 15 minutes.

3.6.2 Measurement procedure

In order to verify combustion efficiency the following measurements must be implemented:

- assess combustion air from the boiler installation room;
- assess flue gas temperature and CO2 from the special sampling port passing through the flue gas venting duct.

If sampling port is not present, it must be provided by the boiler operation and maintenance manager in compliance with the prevailing regulations and standards.

Sampling port must be equipped with a special sealing and must be correctly closed after each reading.

Allow boiler to reach working temperature before taking any measurement.

3.7 Connection to gas mains

Cross-section gas pipe size must be chosen depending on its length, layout pattern, gas flow rate.

Gas supply pipe cross-section must be equal or greater than boiler gas pipe.



DANGER

Comply with installation standards enforced in the country where the boiler is installed which are considered as fully transcribed in this booklet.

Remember that before operating an indoor gas distribution system and before connecting it to a meter, it must be checked for leaks.

If some system parts are not visible, the leak test is to be carried out before the pipes are covered.

Leak test is NOT to be carried out employing flammable gas: use air or nitrogen for this purpose.

Once gas is in the pipes, leak test by a naked flame is forbidden; use specific products available on the market.

When connecting the boiler to gas supply network, it is COMPULSORY to install an appropriately sized gasket (A) made from suitable material (see Fig. 8 Connection to gas mains).

The boiler gas inlet coupling is NOT suitable for hemp, teflon tape or similarly made gaskets.

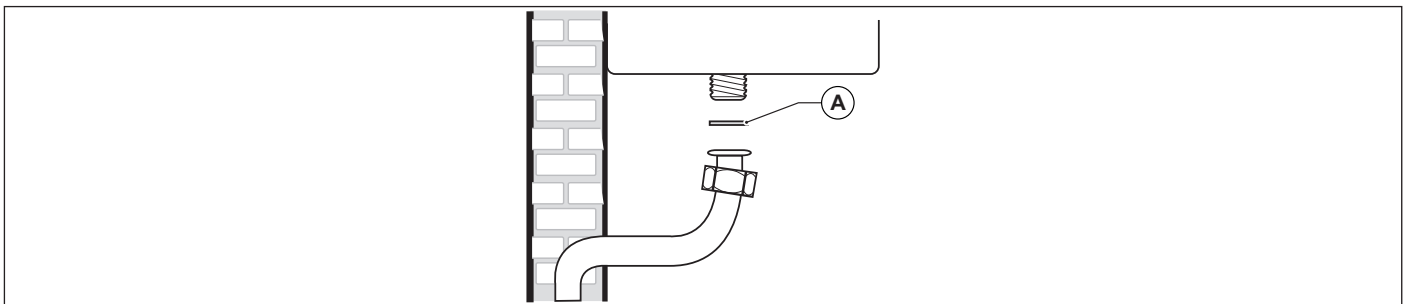

Fig. 8 Connection to gas mains

3.8 Hydraulic connections

3.8.1 Central heating

Prior to installing the boiler, the hydraulic system is to be cleaned in order to remove impurities; they could be present in system components and damage the pump and the heat exchanger.

The CH outlet and return pipes must be connected to the respective 3/4" connectors **M** and **R** on the boiler (see Fig. 5 Paper template).

When calculating the cross section of CH system pipes, bear in mind load losses induced by radiators, thermostatic valves, radiator gate valves, and the configuration of the system itself.



WARNING

It is advisable to convey the discharge flow of boiler safety valve to the sewer system. Should the above precaution not be implemented and the safety valve be activated, boiler room flooding may occur.

The manufacturer shall not be held responsible in case of damage to people, animals, or property due to failure to follow the above mentioned instructions.

3.8.2 DHW

Prior to installing the boiler, the hydraulic system is to be cleaned in order to remove impurities; they could be present in system components and damage the pump and the heat exchanger.

Cold water inlet and DHW outlet shall be connected to the boiler through the dedicated 1/2" **F** and **C** fittings (see Fig. 5 Paper template).

Hardness of water supplied to the boiler may increase the plate heat exchanger cleaning/replacement intervals.



WARNING

Depending on the hardness of the mains water supply, ascertain whether or not to install appropriate domestic water treatment systems using water treatment products suitable for drinking water and compliant with the regulations and standards in force in the country of installation.

Water treatment is always advisable when water supplied to the boiler is more than 20°F hard.

Water supplied by commonly marketed water softeners, due to PH level induced in water, may not be compatible with some components in the system.

3.9 Connection to electrical mains

The boiler is supplied with a three-poled power cable, already connected to the electronic board and it is provided with a safety clamp.

The boiler is to be connected to a 230V-50Hz electrical power supply.

When connecting it to power mains, follow correct phase / neutral polarity sequence.

Installation standards must be complied with and they are herein considered as entirely transcribed.

An easily accessible two-poled switch, with a minimum 3 mm distance between contacts, is to be installed ahead of the boiler. The switch is to allow power supply cut-off in order to safely perform maintenance and service procedures.

Power supply to the boiler must be fitted with a residual-current circuit breaker having suitable disconnection capacity. Electric power supply must be properly earthed.

The above mentioned safety measure must be verified. If in doubt, ask a qualified technician to thoroughly check the power network.



WARNING

The manufacturer cannot be held responsible for any damage caused by failure to earth the system correctly: gas, water, or CH system pipes are not suitable for grounding power networks.

3.10 Connection to ambient thermostat (optional)

The boiler is designed to be connected to an ambient thermostat (optional, not compulsory).

Ambient thermostat contacts must be properly sized in compliance with a load of 5 mA at 24 Vdc.

The ambient thermostat cables must be connected to terminals (1) and (2) of the electronic board (see *Wiring diagram*) after eliminating the jumper supplied as a standard with the boiler.

The ambient thermostat cables are not to be grouped together in the same sheath as power mains supply cables.

3.11 Installation and operation with Open Therm Remote Control (optional)



WARNING

Only use original Remote Control Units supplied by the manufacturer.

The correct operation of the Remote Control itself and of the boiler is not guaranteed if non original Remote Control units not supplied by the manufacturer are used.

The boiler may be connected to an Open Therm Remote Control (non-compulsory optional accessory supplied by manufacturer).

The Remote Control must only be installed by qualified personnel.

To install the Remote Control, refer to the instructions provided with the Remote Control itself.

The Remote Control must be installed on an indoor wall at a height of approximately 1.5 m from the floor and in a suitable location for measuring ambient temperature: do not install in recess or corners, behind doors or curtains, and install away from heat sources, direct sunlight, air draughts and water sprays.

The Remote Control cables must be connected to terminals 3 and 4 of the electronic board.

The Remote Control connector is protected against inverted polarity, and the connections may be inverted.



WARNING

Do not connect the remote control to mains electrical power 230 V ~ 50 Hz.

The remote control wiring must not be grouped together in the same sheath as the power cables: if the cables are sheathed together, electrical interference from the power cables may compromise the functions of the Remote Control;

For complete instructions on how to program the Remote Control, refer to the instruction manual included in the Remote Control kit.

Board and Remote Control communicate in each operating mode: OFF, SUMMER, WINTER, CH ONLY.

Boiler display layout corresponds to the setting made from the Remote Control, as for the operating mode.

The remote control may be used to view and set a number of special parameters denominated **TSP** parameters and reserved solely for qualified technicians.

TSP0 parameter sets default data table and restores all factory settings, cancelling all preceding modifications on single parameters.

If a single parameter is found to be incorrect, the value given in the default value table is restored.

If the user attempts to set a value not within the permissible range for the parameter, the new value is rejected and the existing value is maintained.

3.12 TSP parameters

The boiler operation is controlled by several parameters.

To modify parameters press buttons **Reset** and **- CH** together for 3 seconds.

Scroll through the parameters by pressing **CH +/-** buttons.

As soon as you reach the one to be modified, press **ok**.

The  symbol turns on to indicate that you can edit the parameter value.

The parameter value can be edited using **CH +/-** buttons.

To confirm modification press **Ok**.

To exit the parameter editing mode press button **Reset**.

Parameter	Description	Configurable value range	Default values	Notes
P0 - TSP0	Fuel gas type	0 ÷ 1	According to the model	0 = LPG; 1 = natural gas
P3 - TSP3	Boiler type selection	1 ÷ 3	According to the model	1 = combined instantaneous; 2 = heating only; 3 = with water heater
P6 - TSP6	Ignition power setting	0 ÷ 100 % (min-max)	0%	With P6=0 ignition with ramp. With P6≠0 ignition at the set power (P6=1 minimum power ÷ P6=100 maximum power)
P7 - TSP7	CH maximum output	10 ÷ 100%	100%	n.a.
P10 - TSP10	Heating output curves	0 ÷ 3	1,5	Resolution 0.05
P11 - TSP11	Heating thermostat timing	0 ÷ 10 min.	4	n.a.
P12 - TSP12	CH power rising ramp timer	0 ÷ 10 min.	1	n.a.
P13 - TSP13	Timer for CH post-circulation, freeze protection and flue cleaning function	0 ÷ 180 sec.	30	n.a.
P15 - TSP15	Water hammer protection delay, configurable	0 ÷ 3 sec.	0	n.a.
P16 - TSP16	Ambient thermostat/remote control reading delay	0 ÷ 199 sec.	0	n.a.
P17 - TSP17	Multifunction relay setting	0, 1, 3	0	0 = shut-down and malfunction; 1 = ambient thermostat 1 request/Remote control; 2 = solar; 3 = ambient thermostat 2 request
P27 - TSP27	Heating timer reset temperature	35 ÷ 78 °C	40 °C	n.a.
P28 - TSP28	Hydraulic setting for management of deviating valve relay	0 ÷ 1	0	0 = recirculating pump + deviating valve; 1 = double pump
P29	Setting of default parameters (except P0; P1; P2; P17; P28)	0 ÷ 1	0	0 = user parameters; 1 = default parameters

Tab. 5 Limits to be set for TSP parameters and default values in relation to boiler type (TSP0) - I

Parameter	Description	Configurable value range	Default values	Notes
P30	Display of external temperature	n.a.	n.a.	only with external probe connected
P31	Display of flow temperature	n.a.	n.a.	n.a.
P32	Nominal calculated flow temperature	n.a.	n.a.	only with external probe connected
P42	Displaying of plate DHW temperature	n.a.	n.a.	
P50	Display of boiler type	C; B	According to the model	C = forced draught; B = natural draught
P51	Display of most recent boiler shut-down	n.a.	Fault code	n.a.
P52	Display of penultimate boiler shut-down	n.a.	Fault code	n.a.
P53	Display of third last boiler shut-down	n.a.	Fault code	n.a.
P54	Display of fourth last boiler shut-down	n.a.	Fault code	n.a.
P55	Display of fifth last boiler shut-down	n.a.	Fault code	n.a.
P56	Number of faults since last reset	n.a.	n.a.	n.a.
P57	Board use month displaying	n.a.	n.a.	n.a.
P95	Display of reset shut-down and fault	0 ÷ 1	n.a.	0 = OFF; 1 = shut-downs and faults reset

Tab. 6 Limits to be set for TSP parameters and default values in relation to boiler type (TSP0) - II

3.12.1 Installation of the (optional) external probe and sliding temperature operation

The boiler can be connected to an (optional) external temperature probe (optional, provided by the manufacturer) for sliding temperature operation.



WARNING

Only original external temperature probes supplied by the manufacturer must be used.

If non-original external temperature probes are used, correct operation of the boiler and external probe cannot be guaranteed.

The external temperature probe must be connected by means of a double insulated wire, minimum cross-section 0.35 sq.mm.
The external probe must be connected to terminals (5) and (6) of boiler electronic board.



WARNING

The temperature probe cables must NOT be routed together with power cables.

The temperature probe must be installed on an outside wall facing NORTH - NORTH EAST, in a position protected from weather.

Do not install near a window, ventilation openings or sources of heat.

The external temperature probe automatically modifies the CH flow temperature in relation to:

- Measured external temperature.
- Selected thermoregulation curve.
- Selected fictitious ambient temperature.

The thermoregulation curve is selected via parameter **P10**.

During adjustment, the set value will flash on LCD. Such value can also be read as parameter **TSP10** on the Remote Control (when installed).

The relation between parameter **TSP10** setting and the thermoregulation curve coefficient is the following:

- coefficient = TSP10 value / 84.67

The fictitious ambient temperature is set using **CH +/-** buttons that, with external probe installed, no longer work to set the heating water temperature (see *Operation with external probe (optional)* on page 13).

Through boiler parameter **P30** it is possible to display the value of the outside temperature detected by the external probe.

The figure shows the curves for a fictitious ambient temperature of 20°C. Parameter **P10** allows selecting the curve value shown (see Fig. 9 Thermoregulation curves).

If fictitious ambient temperature value is edited on boiler display, the curves shift up or down, respectively, by the same amount.

With a fictitious ambient temperature setting of 20°C, for example, if you select the curve corresponding to parameter 1 and the outdoor temperature is -4°C, the CH flow temperature will be 50°C.

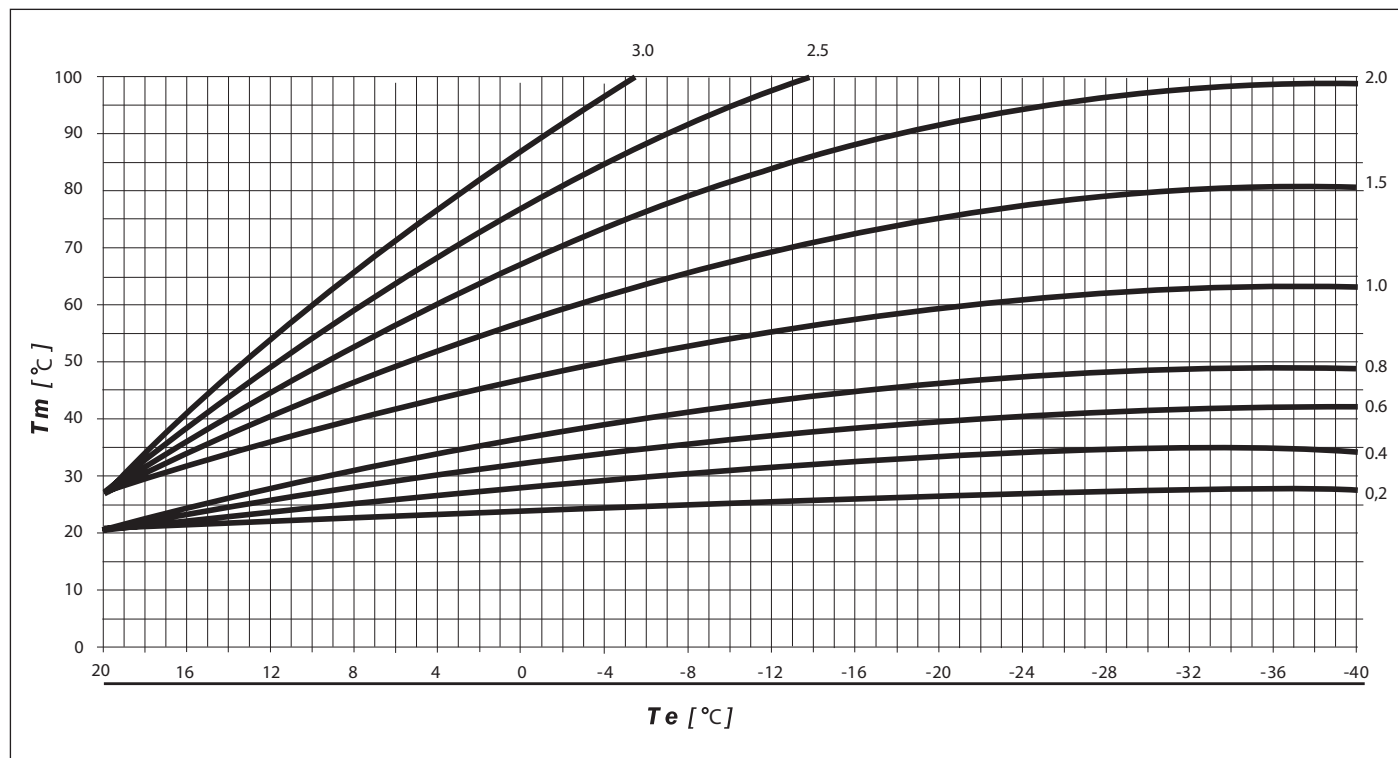

Fig. 9 Thermoregulation curves

Tm indicates flow water temperature in °C

Te indicates external temperature in °C

3.13 Filling the system

Once all boiler connections have been completed, CH system can be filled.

The procedure is to be cautiously carried out, following each step:

- Open the bleeding valves on all radiators and verify the boiler automatic valve operation.
- Gradually open the relevant filler cock, checking any automatic bleeding valves installed in the system properly work (see Fig. 2 Filler cock).
- Close all radiator bleeding valves as soon as water starts coming out.
- Check on pressure gauge that water pressure reaches the 1÷1.3 bar reading.
- Shut the filler cock and bleed any air out again, by opening the air bleeding valves on radiators.
- Start the boiler and bring the system to working temperature, stop the pump, and repeat air bleeding procedure.
- Allow the system to cool and restore water pressure to 1÷1.3 bars.



WARNING

The low water safety pressure switch will not electrically enable the burner ignition when water pressure is below 0.4-0.6 bar.

The CH system water pressure must not be lower than 1 bar. Otherwise, fill the heating system.

The procedure is to be followed while the system is cold.

Pressure gauge is used to read pressure inside the heating circuit.



WARNING

As for water treating in the domestic heating systems in order to optimise efficiency and safety, ensure a long life, trouble-free operation of auxiliary equipment, minimise power consumption, thereby integrating the standards and rules in force in the country of installation, it is recommended to use specific products suitable for multi-metal heating systems.

3.14 Starting up the boiler

3.14.1 Preliminary checks

Before starting the boiler, check that:

- The flue gas venting duct and the relevant terminal are installed in conformity with the instructions: with the boiler operating, there must be no leakage of combustion by-products from any of the gaskets.
- The supply power to the boiler must be 230 V ~ 50 Hz.
- the heating system is correctly filled with water (pressure gauge reading 1÷1.3 bar).
- Any shut-off cocks in the system pipes are open.
- the mains gas type is correct for the boiler calibration: convert the boiler to the available gas if necessary (see *Adaptation to other gas types and burner adjustment* on page 39). This operation is to be exclusively carried out by qualified personnel.
- The gas supply cock is open.
- There are no fuel gas leaks.
- The main switch installed adjacent to the boiler is turned on.
- The 3-bar safety valve is not stuck.
- There are no water leaks.

3.14.2 Switching on and switching off

To switch the boiler on and off, refer to the “**Instructions for the User**” (see *Instructions for the user* on page 8).

3.15 Available head

The boiler is equipped with a high-efficiency circulation pump.

Circulation pump speed can be set during heating and DHW modes, editing the relevant "super technical" parameters of the boiler.



WARNING

Circulation pump operating speeds are set during production.

For a correct operation of the boiler, it is recommended not to change factory setting.

Should it be necessary to change circulation pump settings, contact a Service Centre.

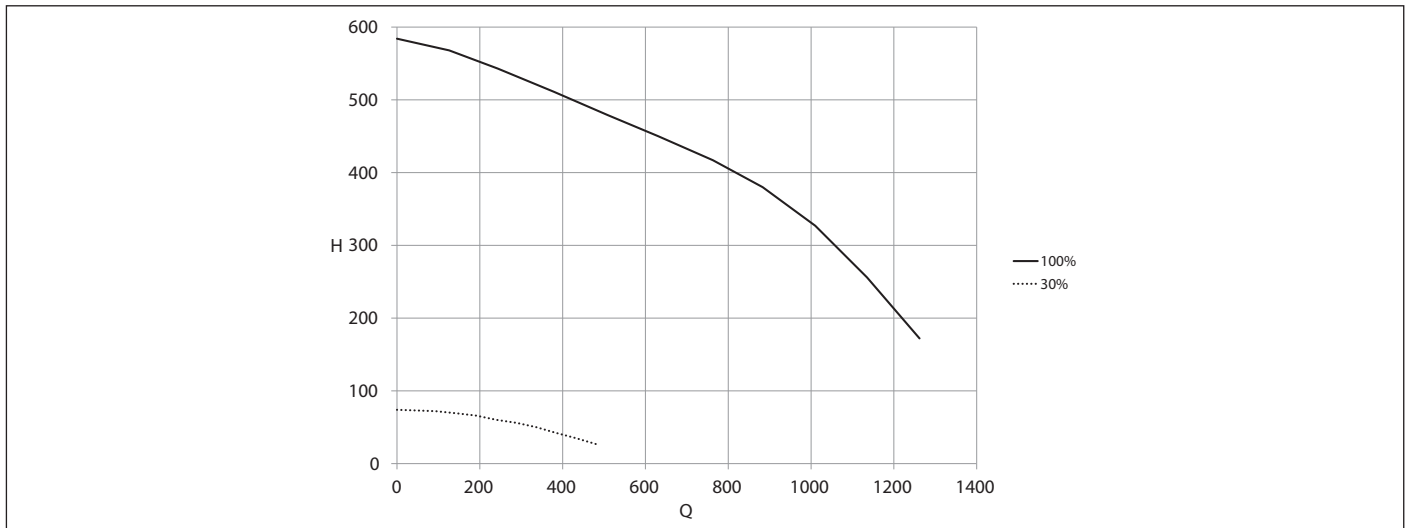

Fig. 10 Available head

Q Flow rate (l/h)

H Available head (mbar)

3.16 Wiring diagram

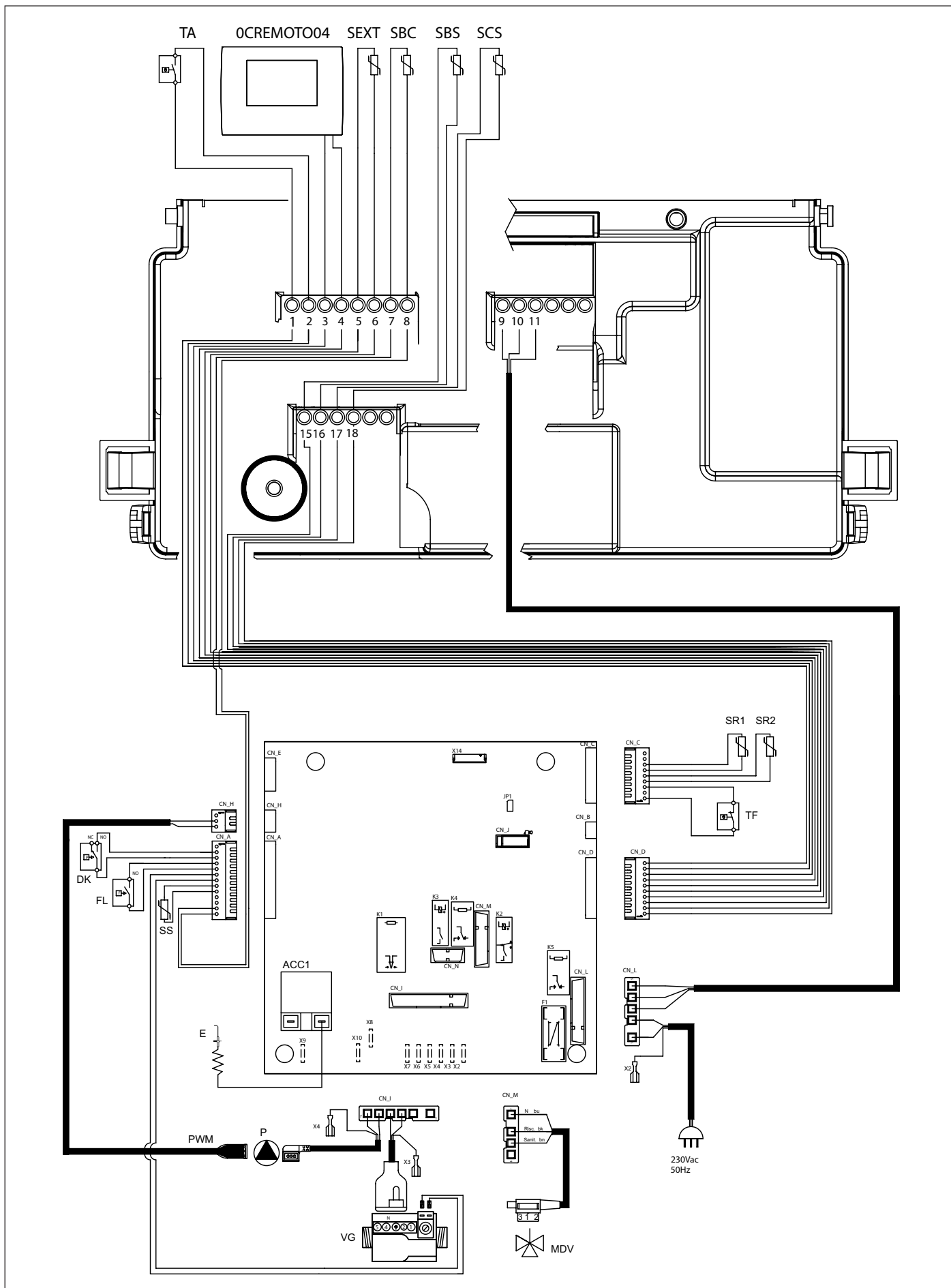

Fig. 11 Wiring diagram CTN

Internal connections

- DK:**low water pressure switch
SR1-SR2:CH NTC probe 10k Ohm at 25°C B=3435 (double)
TF:flue gas thermostat
VG:gas valve
P:boiler pump
PWM:PMW signal cable for circulation pump
FL:flow switch
SS:NTC DHW probe 10k Ohm at 25 °C B=3435
E:ignition/flame detection electrode
CN_A-CN_M:Load/signal connectors
X2-X7:ground connectors
MDV:electric deviating valve

Connections performed by the installer

- 1-2:**room thermostat (TA)
3-4:Remote Control
5-6:NTC external probe 10k Ohm at 25 °C B=3977 (SEXT)
7-8:not used
9-10-11:Programmable relay (230 Vac 5A cosfi=1)
9:phase (NO)
10:phase (NC)
11:neutral (COMMON)
15-16:not used
17-18:not used

3.16.1 Relationship between temperature and nominal resistance of all NTC probes

T (°C)	0	2	4	6	8
0	27203	24979	22959	21122	19451
10	17928	16539	15271	14113	13054
20	12084	11196	10382	9634	8948
30	8317	7736	7202	6709	6254
40	5835	5448	5090	4758	4452
50	4168	3904	3660	3433	3222
60	3026	2844	2674	2516	2369
70	2232	2104	1984	1872	1767
80	1670	1578	1492	1412	1336
90	1266	1199	1137	1079	1023

Tab. 7 Relationship between "Temperature and Nominal resistance" for temperature probes

3.17 Adaptation to other gas types and burner adjustment



WARNING

This boiler is built to run on the type of gas specified on the packaging and on the boiler rating plate.

Any later transformation is to be exclusively carried out by qualified personnel, using manufacturer designed accessories and following the procedure and adjustment instructions for an accurate boiler setting-up.

- remove the main burner;
- remove nozzles from main burner replacing them by new gas type correct diameter ones;



WARNING

The copper gaskets must be installed.

- reinstall the main burner;
- change **P0** parameter value (see table).

Gas	P0
G20	00
G30	01
G31	01

3.17.1 Gas valve setting

Maximum heating output adjustment

- Check the flow pressure value (see *Operating data* on page 21);
- Remove the plastic cover **A** at the top of the modulator coil, protecting the pressure regulator adjuster screws;
- Connect a pressure gauge to the pressure measurement point **IN** to check the input **OUT** and the output pressure;
- Select boiler operating mode "WINTER" or "CH ONLY" by pressing the "Operating mode" button © on the control panel.
- To activate the flue cleaning function, press and hold the buttons "info" and "Reset" simultaneously for 3 seconds. The CH flow temperature and the  symbol are shown on the LCD display;
- Turn the brass maximum pressure adjuster nut **B** CLOCKWISE to increase the pressure at the nozzles, turn ANTICLOCKWISE to reduce the pressure at the nozzles;
- For LPG operation, turn brass nut **B** fully CLOCKWISE.

Minimum heating output adjustment

- Electrically disconnect the modulator coil **D**;
- Switch on the burner and check that the "MINIMUM" pressure value matches the value indicated (see *Operating data* on page 21);
- To adjust the pressure, hold the brass nut **B** in place using a 10mm spanner (fig. 23, fig. 24 or fig. 25) and turn the plastic screw **C** CLOCKWISE to increase the pressure, or ANTICLOCKWISE to reduce it;
- Re-connect the electrical wiring to modulation coil.

Final settings

- turn the boiler on and check its correct operation;
- measure the minimum and maximum gas valve pressures again;
- adjust as necessary.
- Install protective plastic cap **A** on to the screws;
- close gas pressure test points;
- check for gas leaks.

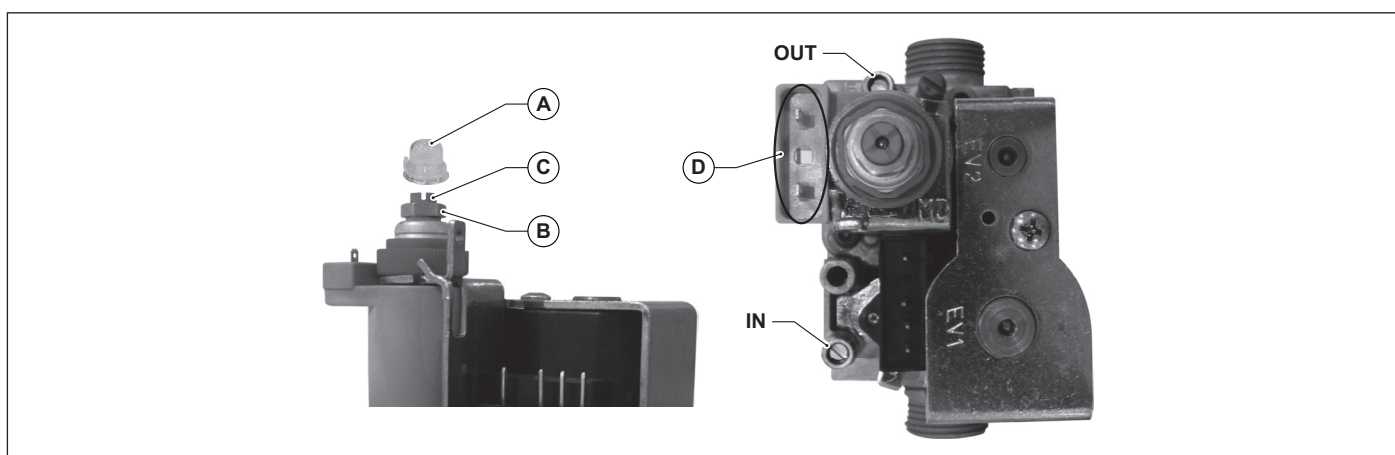

Fig. 12 SIT 845

4. Testing the boiler

4.1 Preliminary checks

Before testing the boiler, it is recommended to check the following:

- the flue gas venting duct and the relative terminal are installed in conformity with the instructions: **there must be no leakage of combustion by-products from any of the gaskets.**
- the supply power to the boiler must be 230 V ~ 50 Hz;
- the system is correctly filled with water (pressure gauge reading 1 to 1.3 bar);
- any shut-off cocks in the system pipes are open;
- the mains gas type is correct for the boiler calibration: convert the boiler to the available gas when necessary; this operation must only be performed by qualified technical personnel;
- the gas supply cock is open;
- **there are no fuel gas leaks;**
- the main switch installed ahead of the boiler is turned on;
- the 3-bar safety valve is not stuck;
- there are no water leaks;



WARNING

Should the boiler not be installed in compliance with the prevailing laws and standards, notify the system supervisor and do not test the boiler.

4.2 Switching on and switching off

To switch the boiler on and off, refer to the “**Instructions for the User**”.

5. Maintenance



WARNING

Any maintenance (and repair) work must only be carried out by qualified personnel.

The user is strongly advised to have the product serviced and repaired by a service centre or qualified personnel. Appropriate boiler maintenance ensures efficient operation, environment preservation, and safety for people, animals and objects.

The boiler must be serviced at least once every year.



WARNING

Disconnect electric power supply before starting any maintenance procedure, involving replacement of components and/or cleaning inside parts of boiler.

5.1 Maintenance schedule

Maintenance operations include check and cleaning procedures. In particular:

Inspections and checks

- Check general integrity of the boiler.
- Check boiler and network gas supply for leakage.
- Check gas supply pressure to boiler.
- Check minimum and maximum gas pressures to boiler nozzles.
- Check boiler ignition sequence.
- Check the condition and seal integrity of the flue gas venting ducts.
- Check operation of safety thermostat installed on the draught excluder.
- Check the condition of the draught excluder.
- Check that there is no flue gas return into the room and that the flue gases are vented correctly.
- Check integrity of safety devices of the boiler in general.
- Check for water leaks and oxidised areas on the boiler's couplings.
- Check efficiency of the system safety valve.
- Check expansion vessel filling pressure.
- Check water pressure switch efficiency.

The following cleaning is to be done

- Clean the general interior of the boiler.
- Clean the gas nozzles.
- Clean the draught excluder.
- Clean the ventilation grille in the room in which the boiler is installed.
- Clean the heat exchanger.

When checking the boiler for the very first time, also verify:

- Boiler room suitability.
- The ventilation apertures in the room in which the boiler is installed.
- Diameter and length of flue gas system ducts.
- Boiler installation in accordance to this "Installation use and maintenance" manual instructions.



WARNING

Should the boiler not operate correctly, while not posing danger to people, animals or property, notify the system supervisor both verbally and in writing.

5.2 Combustion analysis

The combustion parameters of the boiler, which have to be checked in order to determine efficiency and emissions, must be measured in compliance with applicable legislation and standards.

6. Decommissioning, disassembly and disposal



Warning

If you decide to definitively decommission the boiler, have decommissioning, disassembly and disposal procedures carried out by qualified personnel, only.

The user is not authorised to carry out such operations.

Decommissioning, disassembly and disposal operations must be performed with boiler cold and disconnected from gas and power mains.

The materials the boiler is made of can all be recycled.

Once disassembled, boiler must be disposed of in accordance with the national prevailing regulations.

7. Malfunctions, possible causes and solutions

7.1 Troubleshooting

BOILER STATUS	MALFUNCTION	PROBABLE CAUSE	USER'S TASKS	QUALIFIED PERSONNEL'S TASKS	
E01*	Burner does not ignite.	Gas supply failure.	Check gas supply. Check gas supply cock or gas network safety valve intervention.		
		Gas valve is disconnected.	Contact qualified personnel	Reconnect it.	
		Gas valve is faulty.	Contact qualified personnel	Replace it.	
		The board is faulty.	Contact qualified personnel	Replace it.	
	Burner does not ignite: no spark.	Ignition/detection electrode faulty.	Contact qualified personnel	Replace the electrode.	
		Electronic board does not ignite. It is faulty.	Contact qualified personnel	Replace electronic board.	
	Burner ignites for a few seconds and goes off.	Electronic board does not detect flame: inverted phase and neutral.	Contact qualified personnel	Verify correct neutral and phase connection.	
		Ignition/detection electrode wire is interrupted.	Contact qualified personnel	Reconnect or replace wire.	
		Ignition/detection electrode faulty.	Contact qualified personnel	Replace the electrode.	
		Electronic board does not detect flame: it is faulty.	Contact qualified personnel	Replace electronic board.	
Ignition heat input setting is too low.		Contact qualified personnel	Increase it.		
Minimum heat input is not set correctly.		Contact qualified personnel	Check burner setting.		
E02*	The flow probe has read a value higher than 105 °C.	CH water does not flow in the system: pipes might be clogged, thermostatic valves might have shut, system stopcocks might be closed.	Contact qualified personnel	Check system status.	
		Circulation pump is blocked or faulty.	Contact qualified personnel	Check the circulation pump.	
E03*	Flue gas pressure switch triggering.	Poor flue draught.	Contact qualified personnel	Check air intake or flue gas venting system and vent grilles in the boiler room.	
		Flue gas thermostat is faulty.	Contact qualified personnel	Replace it.	
E04**	CH system water pressure is low.	The system is leaking.	Check system.		
		Water pressure switch is disconnected.	Contact qualified personnel	Reconnect it.	
		Water pressure switch is not operating: it is faulty.	Contact qualified personnel	Replace it.	

BOILER STATUS	MALFUNCTION	PROBABLE CAUSE	USER'S TASKS	QUALIFIED PERSONNEL'S TASKS
E05**	Flow probe not working.	Flow probe disconnected.	Contact qualified personnel	Reconnect it.
		Flow probe faulty.	Contact qualified personnel	Replace it.
E06**	DHW probe is not working.	DHW probe is disconnected.	Contact qualified personnel	Reconnect it.
		DHW probe faulty.	Contact qualified personnel	Replace it.
E31**	No communication possible with Remote Control.	Connector cable between boiler and remote control disconnected.	Contact qualified personnel	Reconnect it.
		Remote control faulty.	Contact qualified personnel	Replace it.
Boiler is not supplying DHW.	DHW flow switch is not working.	System insufficient pressure or flow rate.	Contact qualified personnel	Check DHW system. Check DHW flow switch filter.
		DHW flow switch probe is faulty or disconnected.	Contact qualified personnel	Replace or reconnect it.
		DHW flow switch is blocked.	Contact qualified personnel	Replace it.
E41**	No communication between board and peripheral devices (panel interface and/or zone/solar boards).	Parameter P60 is not correctly set.	Contact qualified personnel	Set the P60 parameter value according to the number of supplementary boards.
		The communication wires between the zone/solar boards and the boiler board are inverted/damaged.	Contact qualified personnel	Reconnect or replace wirings.
E72**	Boiler does not recognise if it is of the B or C type.	Flue gas exhaust pressure switch is faulty	Contact qualified personnel	Check flue gas pressure switch: replace it if faulty.
		The wires connecting the flue gas pressure switch to the boiler card are damaged or interrupted.	Contact qualified personnel	Reconnect or replace wirings.
		Air intake or flue gas vent flow is not correct.	Contact qualified personnel	Check air intake/flue gas venting ducts: clean or replace if necessary.
E76**	Gas valve modulation coil is not working.	Electronic board and gas valve link is electrically disconnected or faulty.	Contact qualified personnel	Check connection to the gas valve.
		Gas valve modulation coil is faulty.	Contact qualified personnel	Replace gas valve modulation coil.
E99	The max. number of resets from the Remote Control has been reached.	The user has reached the max. number of resettable values from the Remote Control.	Press RESET button	

(*) errors that can be reset by the user by keeping the **RESET** button pressed.

(**) self-resettable errors, they automatically reset as soon as the failure is fixed.

MANUFACTURER'S COMPLIANCE STATEMENT

Gas Directive 2009/142/EC
Efficiency Requirements Directive 92/42/EC
Electromagnetic Compatibility Directive 2004/108/EC
Low Voltage Directive 2006/95/EC
Ecodesign Directive 2009/125/CE
Energy Labelling Directive 2010/30/CE

FONDITAL S.p.A.
having its registered office in
Via Cerreto 40 - 25079 Vobarno (BS), Italy

STATES

that the products

Delfis CTN 24

are manufactured in conformity

1. With the Type described in the CE-Type Examination Certificate and in the CE-Type Examination Certificate **51CP4466/ED**
51CP4467DR/ED

following the provisions of the Directives
Gas Directive 2009/142/EC
Efficiency Requirements Directive 92/42/EC
which satisfy the essential requisites.

2. With the provisions of the **Electromagnetic Compatibility Directive 2004/108/EC**.
3. With the provisions of the **Low Voltage Directive 2006/95/EC**.
4. With the provisions of the **Ecodesign Directive 2009/125/CE**.
5. With the provisions of the **Energy Labelling Directive 2010/30/CE**.

Fondital S.p.A.

For management
Officer i/c Technical Office

Eng. Roberto Cavallini

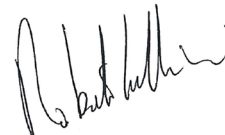

Vobarno, date of issue or of postal mark

Dichiarazione di conformità caldaie

Delfis CTN - Edizione 1 del 18 giugno 2015

This page is intentionally left blank

ATTENZIONE! se vedi questa pagina significa
che devi aggiungere una pagina bianca in fondo
al manuale



OLIBMEEN14

Fondital S.p.A.
25079 VOBARNO (Brescia) Italy - Via Cerreto, 40
Tel. +39 0365/878.31
Fax +39 0365/878.304
e mail: info@fondital.it
www.fondital.com

The manufacturer reserves the right to modify his/her products as deemed necessary, without altering the basic characteristics of the products themselves.

Uff. Pubblicità Fondital IST 04 C 404-01 Giugno 2015 (06/2015)